

**SUBJECT: Electronic Oil Pressure Safety Switch**DATE: February 7<sup>th</sup>, 2012  
AUTHOR: Chris Dahar

<input checked="" type="checkbox"/> PRODUCT	<input type="checkbox"/> SERVICE & PARTS	<input type="checkbox"/> GENERAL
---	--	----------------------------------

Product Name: 06D/06E/06CC Compressors

---

**1.) Description:**

The new Carlyle Oil Pressure Safety Switch (OPSS) is an enhanced means for protecting the compressor from loss of lubrication. The new Carlyle OPSS is an upgrade to the Danfoss MP54 and Penn P545 and will protect the compressor from damage due to low oil differential pressure in recip compressors with oil pump lubrication. The lack/loss of lubrication will result in serious damage of compressor bearings and sliding surfaces.

The new OPSS provides improved ease of installation and eliminates the need for additional tube connections between the compressor and the DP switch.

- Eliminates additional mounting brackets and tubing.
- Reduces the number of potential leak points.
- Improves maintenance and serviceability. Simple quick component replacements without refrigerant reclaim.

**How to Order:**New Carlyle Kit part #: **06DA660170**

Includes:

- **06DA509570, OPSS Electronic Unit**
- **06DA509571, OPSS Screw-in Sensor**
- **06DA660169, Sensor Block Kit**

## 2.) Function:

- The OPSS differential oil pressure switch consists of two parts: a sensor unit and an electronic unit. The electronic unit can easily be disconnected from the sensor without opening the oil/refrigeration circuit.

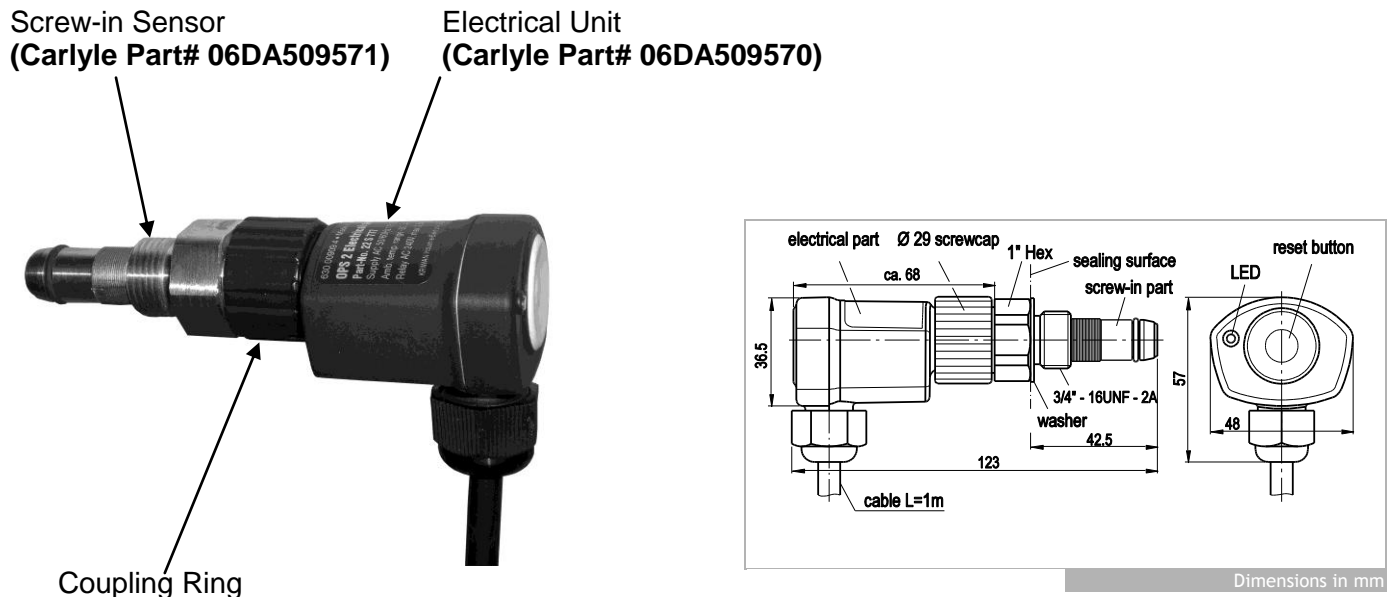

Figure 1

- The OPSS serves to monitor the oil differential pressure of the oil pumps in refrigeration compressors. For this, a screw-in sensor is mounted directly to the pump housing and measures both the compressor's suction and oil pump pressure simultaneously. The screw-in sensor is thereby connected, by the sensor block, to the suction and high pressure side of the oil pump. Thus supplementary pipe connections are not needed.
- The OPSS electrical unit is fastened by a coupling ring to the screw-in sensor and can be removed without opening the oil/refrigeration circuit (not in direct contact with the oil circuit). See figures 1 & 2.

**3.) OPSS Operation:**

- The OPSS is a dual power low oil DP switch 120/240Vac (Blue/Brown wires).
- Compressor Start: Oil pressure monitoring is activated once the supply voltage is applied to the operating recognition signal, which is applied to D1 (violet wire) via an auxiliary contactor or motor contactor (see wiring diagram figure 3). Following a compressor start, the OPSS allows for a 120 second oil pressure transition delay to allow the compressor to reach steady oil pressures. The differential pressure monitoring is activated after the expiration of the 120 second compressor starting transition time.
- A low differential oil pressure (9 psig) for a continuous 120 seconds will lead to a locked switch and trip the compressor off.
- Also, a time integrated low differential oil pressure (9 psig) that is fluctuating 60% of the time  $\leq$  to 9 psig over a 5 minute rolling window will lead to a locked switch and trip the compressor off.
- A manual reset of the relay can be carried out by the built-in push button, or by activating the operating recognition (D1) or by a 5 second power reset.
- The monitoring of internal errors is always active. Any faults that occur in any operational phase will lead to a locked switch off of the relay after 5 seconds and trip the compressor. The potential-free relay contact can be looped into a safety circuit without an auxiliary relay. An installation check monitors for the proper assembly. An LED status will indicate if the OPSS is faulty or not correctly installed (See LED Status Table).
- The built-in LED indicates the actual operating state of the compressor's oil pump pressure. Once the oil DP preset value has been reached (13 psig), the LED light will be off and the OPSS output contacts remain in the closed position (Gray and Orange wires). If the differential oil pressure falls below the cut-out preset value (9 psig) for a continuous 120 seconds or a time integrated low delta P for 120 seconds, the OPSS output contacts will open and shut down the compressor and indicate the status per the LED indicator (See LED Status Table).

**4.) Oil Sensor Block Installation**

1. Remove cover plate bolts, cover plate and gasket from bearing head. (During reassembly be sure that spring and recess cup is in place and do not re-use factory installed gasket.)
2. Install the 1/4" NPT oring seal fitting into the high side oil pump pressure port on the compressor as shown:

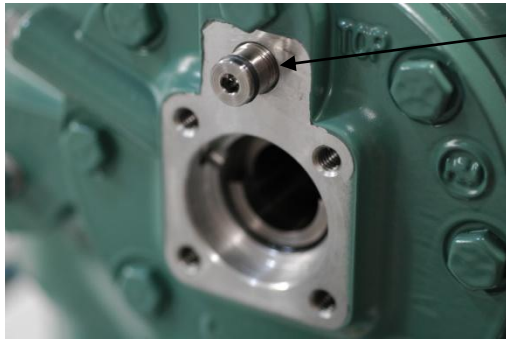

Install 1/4" NPT Oring fitting.  
(P/N 06EA407204)

3. The sensor block gasket (P/N 06DA504473) is installed between the bearing head and sensor block with the bead side facing you. Lightly oil the gasket. Make sure the bearing head surface is clean and free from any debris.



- Next, install the sensor block (P/N 06EA507202) over the gasket and the 1/4" NPT oring seal fitting as shown. Mount the sensor block to the bearing head using the four 5/16"-18 x 1-1/4" allen head bolts provided in the kit. Torque to 15 ft/lbs. (Be sure spring and recess cup are in place).



- Install the OPSS sensor into the Sensor Block. Be sure the copper washer is in-place. Tighten the sensor's 1" hex nut securely to the sensor block (max torque allowable is 55 ft/lbs).



## 5.) Installation and Wiring for OPSS

- 1.) Install the coupling ring end of the OPSS electrical unit to the sensor by hand (figure 2) and secure tightly.
- 2.) The electrical connections for the OPSS electrical unit need to be carried out according to the proposal in the wiring diagram (see figure 3).

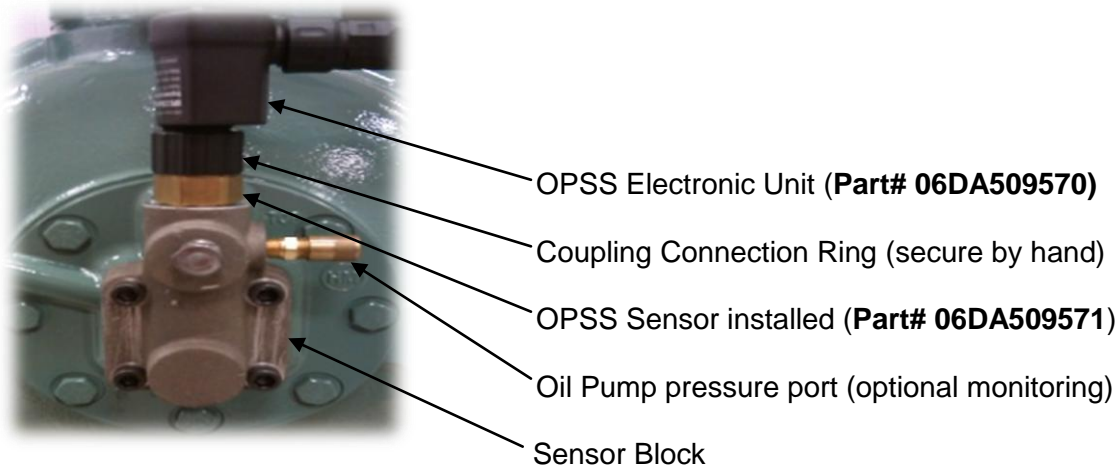
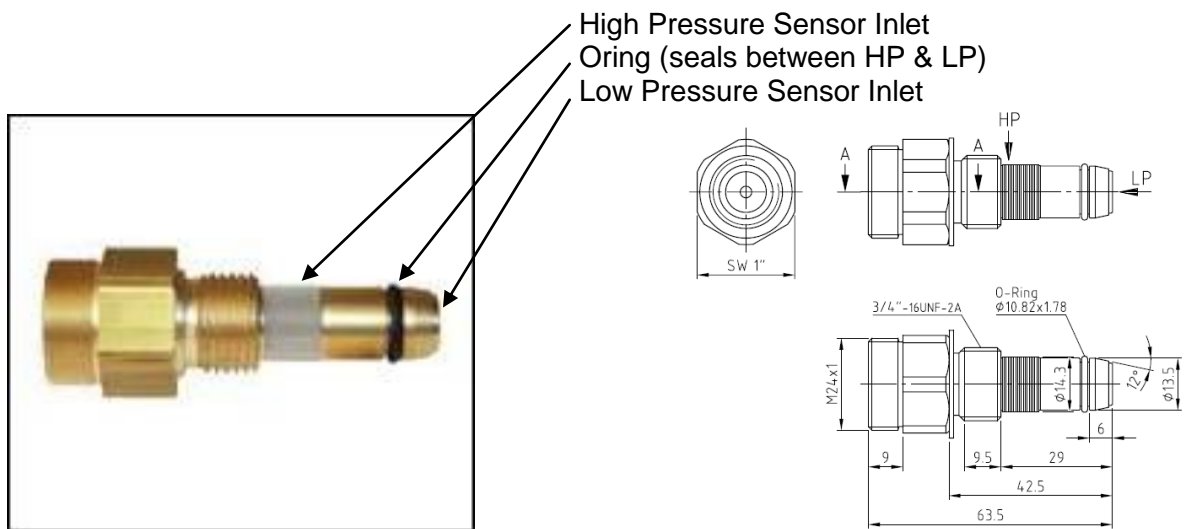

Figure 2



OPSS Sensor

### Note:

The oring on the screw-in sensor provides the barrier between low/high side oil pump pressures. Inspect the oring for any damage before installing the screw-in OPSS sensor.

## 6.) Technical specifications:

Screw-in Sensor Unit	
Permitted temperature	-22F to +194°F
Differential pressure	Cut-out 9psig ±1 psig Reset 13psig ±1 psig
Operating Pressure	435 psig
Electronic Unit	
Connection:	
- Dual voltage	AC 50/60Hz 115-230V - 15...+10%
Connection operating recognition (D1) dual voltage	AC 50/60Hz 115-230V - 15...+10%
Ambient Temperature Range.	-22F to 158F
Delays:	
- Relay On after applying the supply voltage	3s ±1s
- Relay on after previous locking	120s ±5s
- Starting transition time D1 active	5s ±2s
- Relay off (error)	5s ±2s
- Relay off (diff.- pressure missing)	120s ±5s (time integration)
- Reset by interrupting the supply voltage	About 5s
- Reset by button	About 1s
- Reset by operating recognition (D1)	About 1s
Output relay	AC 240V 2.5A C300
Protection class acc. to EN 60529	IP54 in built-in status

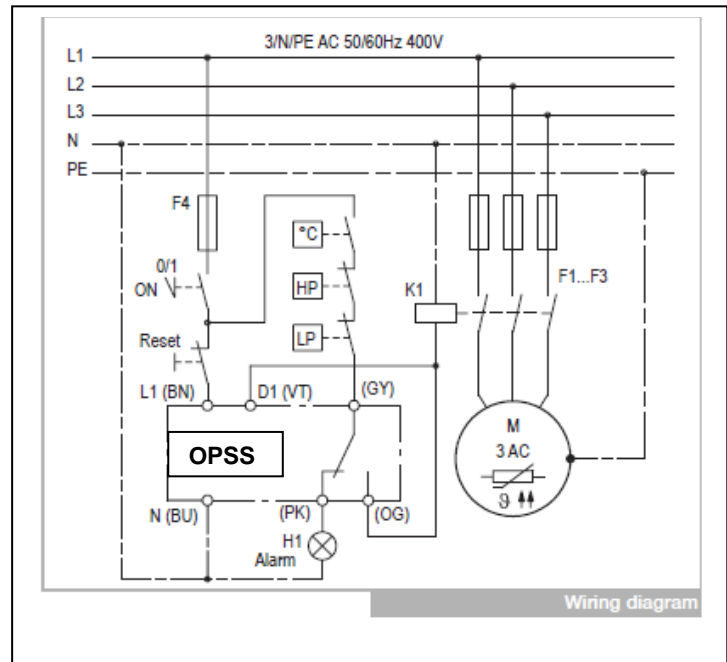

Figure 3

## 7.) Flash code of the red LED:

Flashing 10 times per second:

- Internal Error.
- Voltage Supply too low.
- Electrical unit not completely attached to sensor.
- Operating recognition on but relay still off.

Flashing 1 time per second:

- Reset Delay













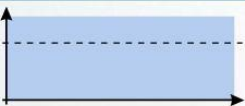

Continuous Light:

- Oil Differential Pressure low.

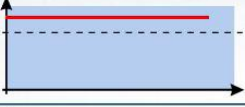
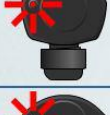
OFF:

- Differential pressure OK, no error.

LED Status Table

		<b>1 Sec Flashing: Reset Delay</b>	
		<b>Continuous Flashing: Oil Differential Low, Compressor Trip.</b>	
		<b>No Light: Differential Pressure Good. Compressor On.</b>	
		<b>Continuous Flashing: Time Integrated Oil Differential Low. Compressor Trip.</b>	
		<b>10 Sec Flashing: OPSS Unit Fault</b>	

## The OPSS can be reset in three different ways:

- Disconnect the module from the power supply for 5 seconds.
- Push the rest button.
- Reset by operating recognition signal (D1), violet wire for 5 seconds.
- Once the module is reset, the compressor is allowed to re-start again after a 120 second time delay.